

# **HSDJETS<sup>®</sup>**

# HSDJETS-182 ASSEMBLY AND DEBUGGING GUIDE

V1.0

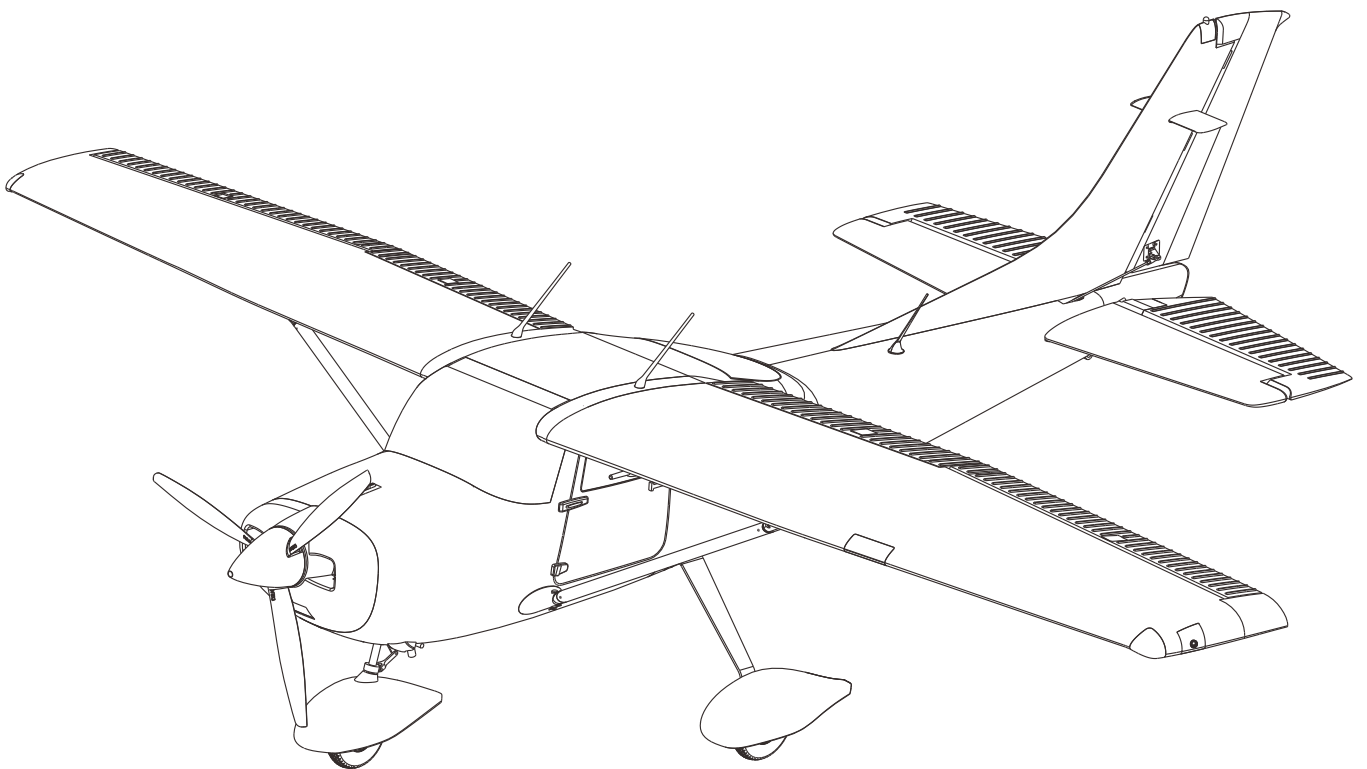

Product S/N:

Want to learn more about the product video,  
pictures, and other matters of attention Please  
log in: [www.hsdr.com](http://www.hsdr.com)

## INDEX

Introduction-----	03
Important hints-----	03
Safety Flight Instructions-----	04
Description of each component-----	05
Install instructions1:Aircraft unpacking (PNP version)-----	06
Install instructions2:Install the landing gear and fuselage-----	07
Install instructions3:Install the left and right flat tails-----	07
Install instructions4:Install the vertical tail-----	08
Install instructions5:Install the wing brace tube-----	08
Install instructions6:Install the main wing-----	08
Install instructions7:Install the radar antenna-----	09
Install instructions8:Install the propeller-----	09
First test and adjustment after assembly1-4:Boot process-----	10
First test and adjustment after assembly5:Aileron detection-----	10
First test and adjustment after assembly6:Aileron adjustment-----	11
First test and adjustment after assembly7:Elevator detection-----	11
First test and adjustment after assembly8:Elevating adjustment-----	12
First test and adjustment after assembly9:Direction detection-----	12
First test and adjustment after assembly10:Direction adjustment-----	13
First test and adjustment after assembly11:Flap detection-----	14
First test and adjustment after assembly12:Flaps adjustment-----	14
First test and adjustment after assembly13:Ground interview and adjustment-----	15
First test and adjustment after assembly14:Center of gravity detection before take-off-----	16
First test and adjustment after assembly15:Center of gravity adjustment-----	16
Landing gear decomposition graph-----	17
Specification and configuration-----	19

## Introduction

Thank you so much for purchasing plane, What you have now is the latest plane product of HSDJETS. This model has the following features:

1. It is difficult to find a larger 2-meter wingspan HSDJETS-182 on the market, with a higher simulated appearance, trifoil propeller, six-sided transparent cabin, simulated instrument panel, two-row four-seater seats and pilots.
2. The electronic equipment configuration of the whole HSDJETS-182 can be called the conscience of the industry:
  - 2.1 Equipped with HSDJETS independently developed MFC-2065 integrated control system, with independent power supply system, supporting dual-rotate S-BUS output, flap compensation and other practical functions.
  - 2.2 Adopt 5055, KV500 external rotation brushless motor, Hobbywing 80A ESC, 7.4V high voltage 25g metal gear digital servo, and simulate aerial light system.
  - 2.3 The HSDJETS-182 is so well-equipped that driven by a 6S, 5200mAh lithium battery, coupled with a 14.5×7 simulated trifoil propeller, the HSDJETS-182 has a more powerful source of power and higher flight

efficiency, cruising The time can be up to 10 minutes.

3. The wings, horizontal tail and vertical tail of HSDJETS-182 all adopt quick disassembly structure. The disassembly process does not need to lock a screw, and it can be quickly assembled in about 2 minutes.
4. The HSDJETS-182's fuselage and wings are connected by a high-precision one-piece quick plug, which is quick to assemble and reliable to connect.
5. The front landing gear is made of all-aluminum CNC, with shock absorption function, and the rear landing gear is made of 7075 extra-hard 3mm thick aviation aluminum, which is strong, strong and impact resistant.
6. Both the front and rear landing gears are equipped with 80mm super-large-diameter tires to adapt to the taxiing of the grass, and optional electromagnetic brake wheels.
7. The classic upper single-wing design, easy to control, stable and good flying.

We believe that plane will bring you excellent flight.  
Before starting, please read our manual carefully.

## Note



**This is not a toy, it has the potentially dangerous, not for children under 14 years. Young people under the age of 14 should only be permitted to operate the model under the instruction and supervision of an adult. Please keep these instructions for further reference after completing model assembly.**

## Important hints

1. Operator should have a certain experience, beginners should operate under the guidance of professional players;
2. Before install, please read through the instructions carefully and operate strictly under instructions;
3. Cause of wrong operation, HSDJETS and its distributors/dealers will not be held responsible for any losses;
4. Model planes players must be on the age of 14 years old;
5. This plane used the EPO material with surface spray paint, don't use chemical to clean, otherwise it will damage;
6. Your should be careful to avoid flying in areas such as public places, high-voltage-intensive areas, near the highway, near the airport of any other place where laws and regulation clearly prohibit;
7. You can not fly in bad weather conditions such as thunderstorms, snow, and etc;
8. Model plane`s battery, don't allowed to put in everywhere. Storage must ensure that there is no inflammable and explosive materials in the round of 2 meter range;
9. Damaged or scrap battery should be properly recycled, it can't discard to avoid spontaneous combustion and fire;
10. In flying field, the waste after flying should be properly handled, it can't be abandoned or burned;
11. In any case, you must ensure that the throttle is in the low position and transmitter switch on, then it can connect the li-po battery in aircraft;
12. Do not try to take planes by hand when flying or slow landing process. You must wait for landing stop and when the blades stop turning, first disconnect the power supply and than carry it;
13. Whether flying or debugging on the ground, always ensure that there is no one in front of the aircraft.

## Safty Flight Instructions

**Strongly suggestion: users while enjoying the flying, please ensure that you are in a safe and reasonable environment.**

1. It is better to try to choose an empty airspace and no obstacles conditions when you fly.
2. Stay away from people, animals, buildings, trees, water and other obstacles during flying.
3. Please keep the radio transmitter in your hand during the flight to control the model at any time to prevent accidents.
4. Please control the height of the aircraft to 120 meters to ensure the flight safety of the flyer and civil aviation. If you are in the area that have restrictions on flying altitude of 120 meters or less, please comply with its regulations. Make sure the model do not go out of sight and cause unnecessary accidents.

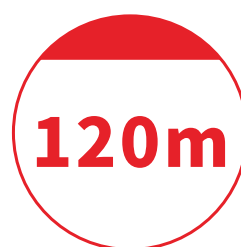
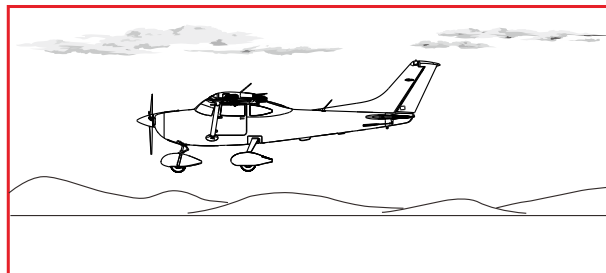

### Flight environment requirements

1. Do not fly in areas such as transmission towers, communication base stations, high-voltage lines, or Wi-Fi hotspots to prevent the radio transmitter signal is interferenced.
2. Do not operate in bad weather, such as: strong winds(wind speed 10 m/s and above), raining, lightning, fog, snow, etc..
3. Flying is not recommended at altitudes above 4,500 meters and in the Arctic and Arctic circles.
4. Do not fly in airports or restricted areas under the relevant laws or regulations.

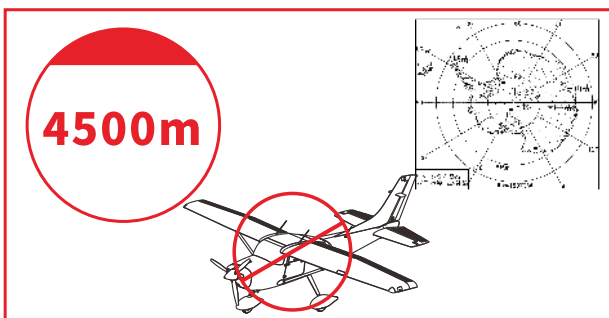
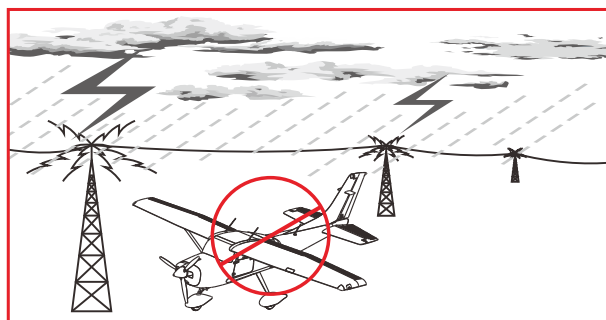
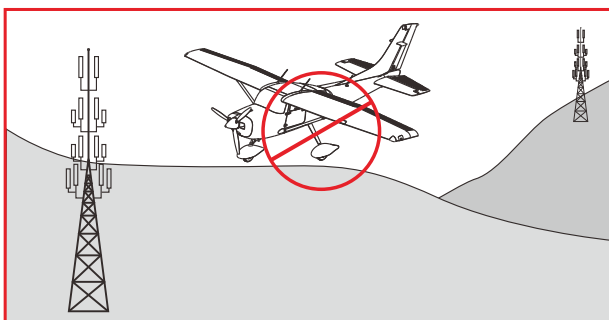

## Description of each component

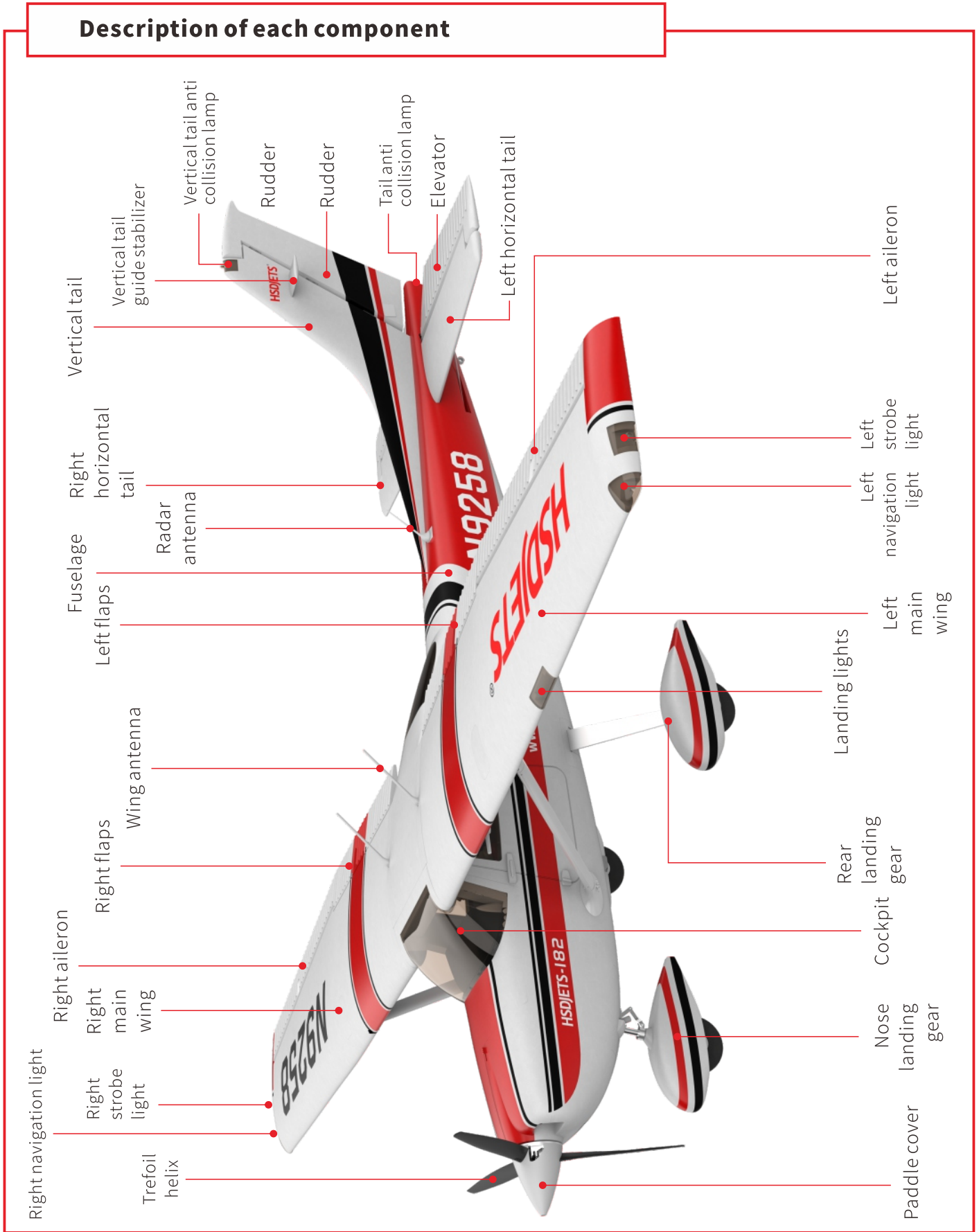

## Install instructions

**1. Aircraft unpacking (PNP version):** take out the fuselage, left and right main wings, propeller, vertical tail, landing gear, left and right horizontal tail, wing diagonal support tube, main wing bolt rod, instruction manual, flat tail bolt rod, vertical tail diversion stabilizer, accessory package and other articles in the carton, and check whether the quantity of packing articles is complete according to the packing list in the manual.



Fuselage×1



Left main wing×1



Right main wing×1



Propeller×1



Vertical tail×1



Landing gear×1



Left horizontal tail×1



Right horizontal tail×1



Wing diagonal tube×1

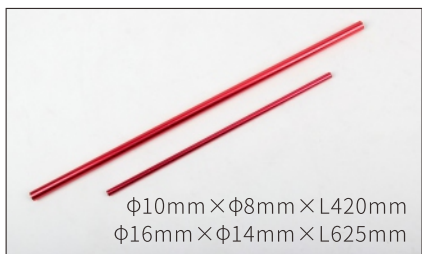

φ10mm×φ8mm×L420mm  
φ16mm×φ14mm×L625mm

Main wing bolt rod×1

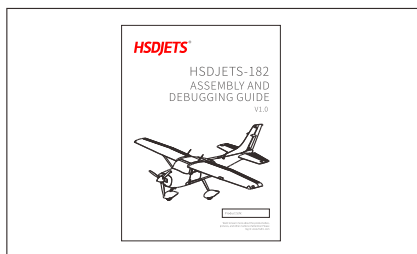

Manual×1

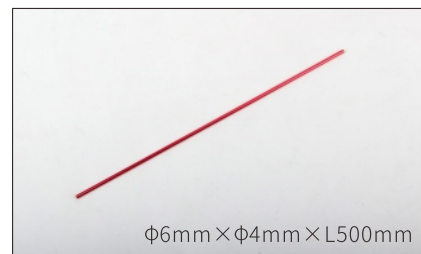

φ6mm×φ4mm×L500mm

Horizontal tail bolt rod×1



Vertical tail diversion stabilizer×1



Accessory Package ×1

100 mm signal line (JR male + JR male) × 4pcs  
Ha3 × 10mm × 4pcs (nose landing gear)  
PM3 × 15mm × 8pcs (rear landing gear)  
PM3 × 10mm × 1pcs (fairing)  
HM3 × 10mm × 4pcs (paddle clamp)  
PA3 × 18mm × 4pcs (wing brace)  
Diagonal brace bolt and safety × 2pcs (wing brace)

## Install instructions

**2. Install the landing gear and fuselage:** Take out the landing gear and fuselage from the PE bag and place them on a flat and clean table. Prepare first. Open the equipment compartment cover at the bottom of the fuselage as shown in the figure. Take out the rear ball head buckle of the front wheel steering wire, and then buckle the front end ball head of the front wheel steering wire on the position of the rocker ball head of the front landing gear, insert the front landing gear into the corresponding slot of the fuselage, and use the screw (PA3 × 10mm × 2pcs), and then buckle the front-wheel steering wire rear end ball head to the original ball head. Align the rear landing gear to the corresponding position of the fuselage (the rear landing gear is divided into left and right, the installation method is the same), put the landing gear on the fixed seat of the main landing gear, and then press the main landing gear fixing piece against the landing gear, Fix it with screws (PM3 × 15mm × 4pcs).

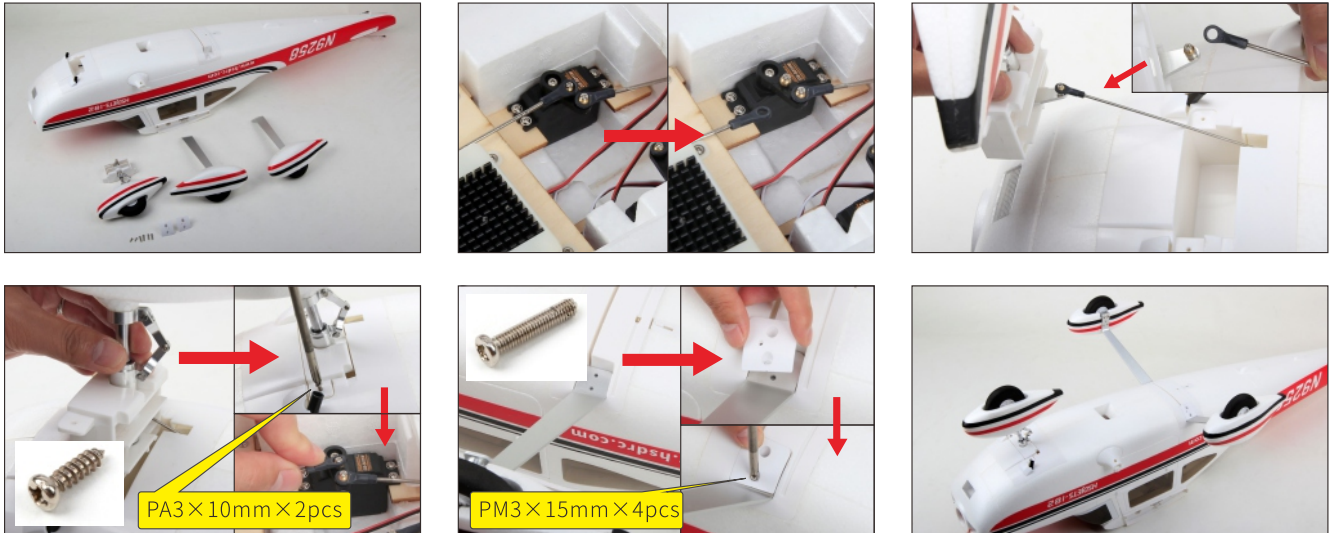

**3. Install the left and right flat tails:** first, pass the flat tailspin rods ( $\phi 6\text{mm} \times \phi 4\text{mm} \times \text{L}500\text{mm}$ ) through the designated holes of the fuselage, make sure that the extensions of the flat tailspin rods at the left and right ends of the fuselage are equal, and then set the left and right flat tail holes. Align the latch rods and insert the latch rods respectively, align the left and right flat tails and the left and right flat tail rudder surface plastic parts, push them into place, and then hear a "PA", indicating that the installation is in place. Then buckle the ball head onto the flat tail to strengthen the plastic rocker ball head. **Note: If you want to be firmer, you can apply EPO glue to the contact sections between the left and right tails and the fuselage before installing.**



**Note: If you want to be firmer, you can apply EPO glue to the contact sections between the left and right tails and the fuselage before installing.**

## Install instructions

**4. Install the vertical tail:** first coat the vertical tail diversion stabilizer with EPO glue and then install it to the corresponding position of the vertical tail, and then install the vertical tail at the designated position of the fuselage. Make sure to connect the vertical tail end and the LED at the fuselage end. The light cable, the color of the wire is to the color, can not be inserted reversely. The signal cable between the vertical tail end and the fuselage end; after pushing it firmly into place, you will hear a "PA" sound, indicating that the installation is in place. Finally, buckle the ball head buckle, and the tail assembly is complete. **Note: If you want to be firmer, you can apply EPO glue to the contact section between the vertical tail and the fuselage before installing.**

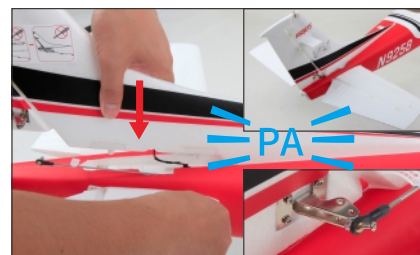
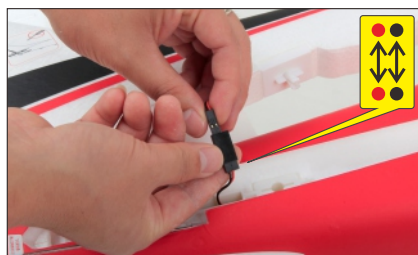
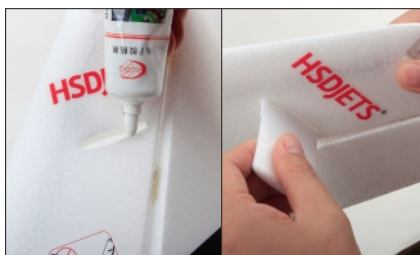

**5. Install the wing brace tube:** install the wing brace tube at the designated position of the wing and fix it with screws (PA3 × 18mm × 2pcs).

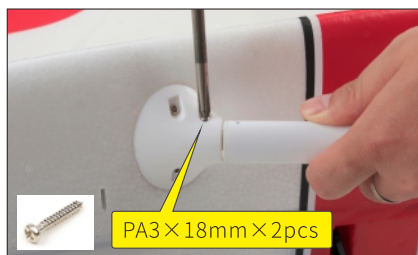
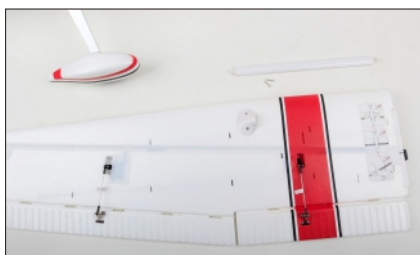

**6. Install the main wing:** Pass the main wing latch rod ( $\phi 16\text{mm} \times \phi 14\text{mm} \times \text{L}625\text{mm}$ ) ( $\phi 10\text{mm} \times \phi 8\text{mm} \times \text{L}420\text{mm}$ ) through the designated hole of the fuselage. Make sure that the main wing latch rods at the left and right ends of the fuselage have the same extension, and then the holes of the left and right main wings are aligned with the main wing latch rods, and insert the latch rods. Before fully inserting, make sure to connect the main wing end and the fuselage end signal cable to ensure that the wing brace tube is inserted into the wing brace tube and the fuselage is fixed. After installing it in place, install the diagonal brace pin into the fixed seat of the wing diagonal brace tube fuselage, install the safety pin, and then insert the wing antenna.

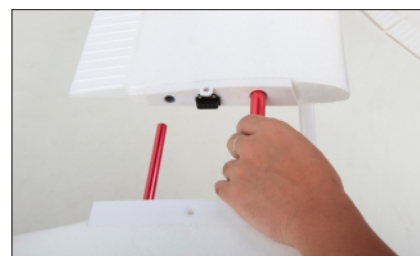
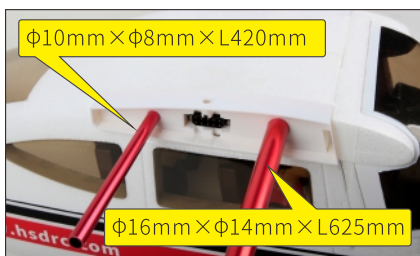

## First test and adjustment after assembly

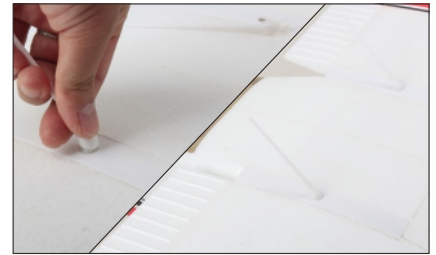
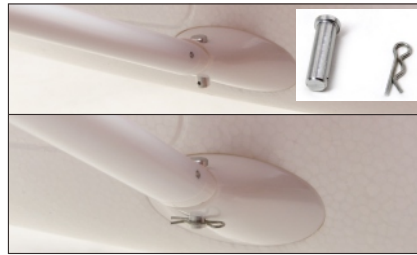

**7. Install the radar antenna:** apply EPO glue to the radar antenna, and then stick it to the corresponding position on the back of the fuselage.



**8. Install the propeller:** Install the propeller clamp at the designated position of the motor, and fix it with a screw (HM3×10mm×4pcs). Remove the propeller clamp nut and washer, install the propeller on the propeller clamp, and then install the washer and nut to tighten with a wrench. Install the fairing on the designated propeller and fix it with screws (PM3×10mm×1pcs). The Cessna body is assembled.

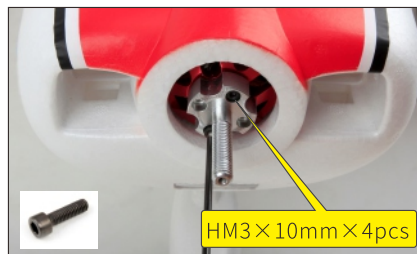

## First test and adjustment after assembly

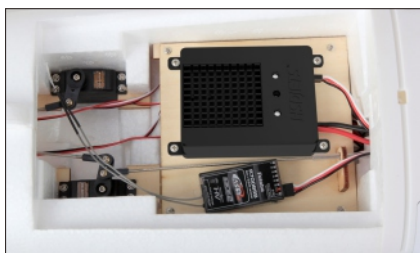

1. Locate the S-BUS line in the MFC-2065 integrated control box and connect it to the S-BUS port of the receiver.

(Note: If the receiver does not support S-BUS, the MFC-2065 integrated control box needs to be connected to the PWM signal line;)



2. Turn on the remote control.



3. Connect the MFC-2065 integrated control box to a set of 2S lithium batteries.

4. MFC-2065 integrated control box S-BUS mode channel setting, the factory channel is: S-BUS Setting.

- |                                   |                                 |
|-----------------------------------|---------------------------------|
| 1. AUX1 CH Aileron (Default CH1)  | 4. AUX4 CH Rudder (Default CH4) |
| 2. AUX2 CH Elevator (Default CH2) | 5. AUX5 CH Flaps (Default CH6)  |
| 3. AUX3 CH Throttle (Default CH3) | 6. AUX6 CH Brake (Default CH5)  |

**5. Aileron detection:** check whether the aileron movement is correct

### Right model throttle radio transmitter



### Aileron standard action

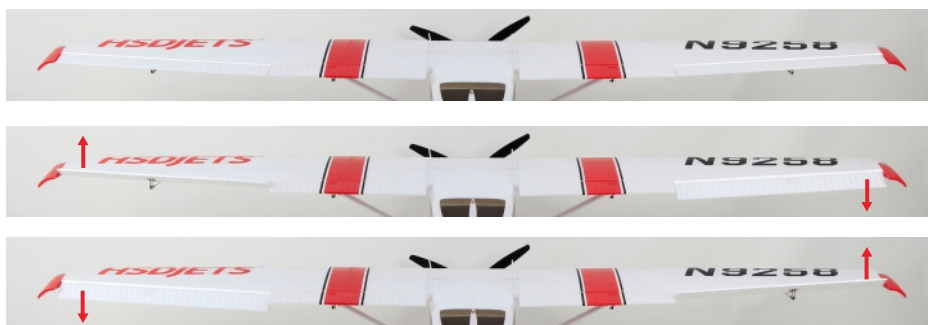

**Note:** If there is no special instruction, this user guide uses the right-hand oil remote control as an example for introduction.

When the aileron action is opposite to the specified action, you can find the servo reverse setting menu in the remote-control menu, and switch forward and reverse in the aileron item bar.

### Right model throttle radio transmitter



### Possible ailerons reverse action

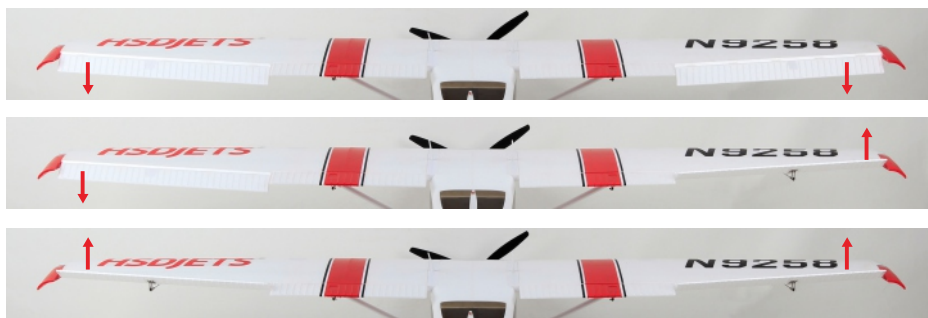

## First test and adjustment after assembly

**6. Aileron adjustment:** After completing the setting, start to adjust the standard position of the rudder surface. The aileron rudder surface should be on the same plane as the wing. If there is upturn or downturn that needs to be leveled, it can be adjusted through physical adjustment or system adjustment;

- (1). Physical adjustment: change the length of the rudder surface by adjusting the length of the lever to keep it on the same plane with the wing;
- (2). System adjustment: fine-tune adjustment through the remote control;

It is recommended to use 80% rudder amount for remote control, adjust the EXP curve under the premise of the same rudder amount, firstly, it is recommended to modulate -30% EXP value; actually adjust according to personal operating habits.



Suggest the amount of servo:

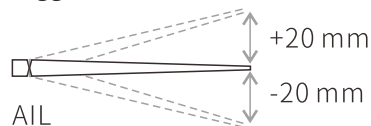

EXP suggest: -30%

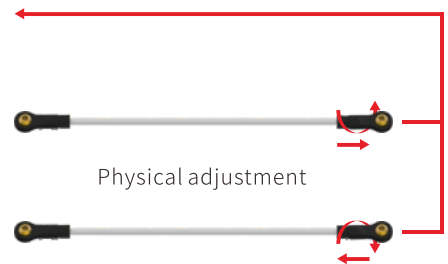
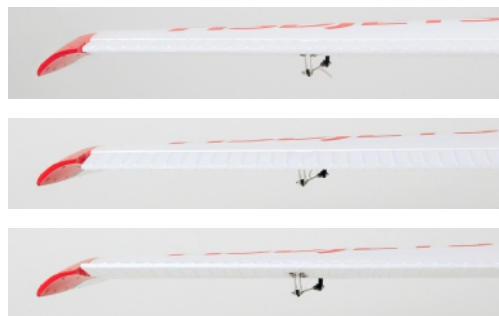

**7. Elevator detection:** check whether the lifting action is correct

Right model throttle radio transmitter



Aileron standard action



Possible ailerons reverse action



**Note:** If there is no special instruction, this user guide uses the right-hand oil remote control as an example for introduction.

When the elevator action is opposite to the specified action, you can find the servo reverse setting menu in the remote-control menu, and switch forward and reverse in the elevator item bar.

## First test and adjustment after assembly

**8. Elevating adjustment:** After completing the setting, start to adjust the standard position of the rudder surface. The elevator surface should be on the same plane as the horizontal tail. If there is upturn or downturn that needs to be leveled, it can be adjusted through physical adjustment or system adjustment;

(1) Physics Adjustment: change the length of the rudder surface by adjusting the length of the lever to keep it on the same plane as the wing;

(2) System adjustment: fine-tune adjustment through the remote control;

It is recommended to use 80% rudder amount for remote control, and the rudder amount does not change. Adjust the EXP curve under the premise, the first suggestion is to modulate the -30% EXP value; the actual adjustment should be based on personal operating habits.

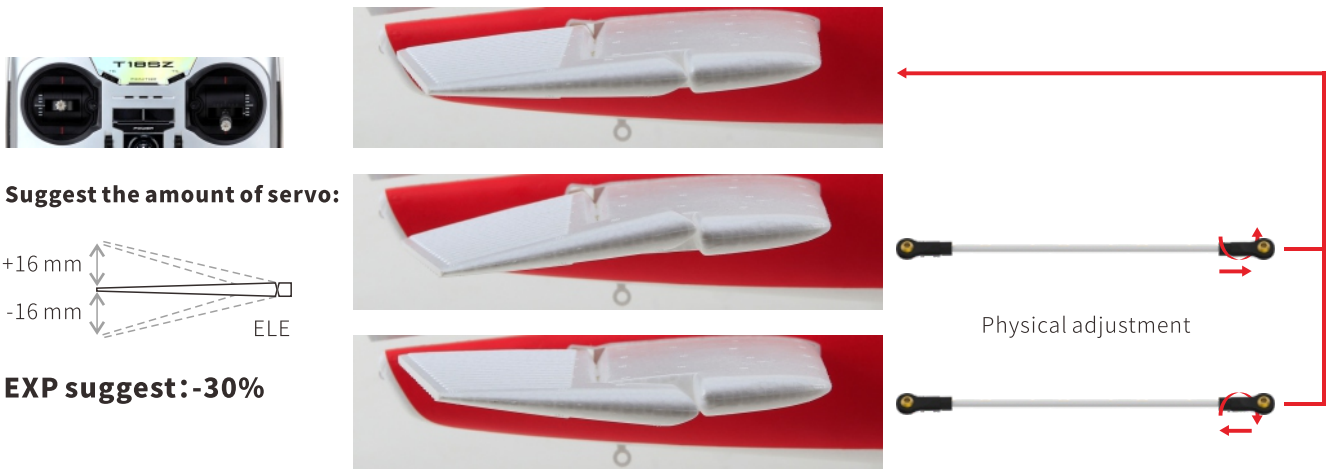

**9. Direction detection:** check whether the direction is correct

### Rudder standard action



**Note:** If there is no special instruction, this user guide uses the right-hand oil remote control as an example for introduction.

## First test and adjustment after assembly

### Possible rudder reverse action



When the rudder action is opposite to the specified action, you can find the servo reverse setting menu in the remote-control menu, and switch forward and reverse in the rudder item bar.

**10.Direction adjustment:** After completing the setting, start to adjust the standard position of the rudder surface. The rudder surface should be in the same plane as the vertical tail. If there is a left or right deviation, it needs to be adjusted to the vertical center, which can be adjusted through physical adjustment or system adjustment:

- (1).Physical adjustment: change the length of the rudder surface by adjusting the length of the lever to keep it on the same plane with the wing;
- (2).System adjustment: fine-tune adjustment through the remote control;

It is recommended to use 80% rudder for remote control, and it should be adjusted according to personal habits;

**Suggest the amount of servo:**

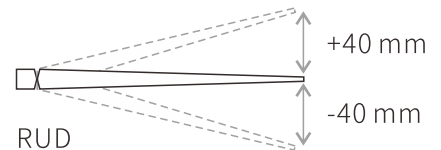

The rudder adjusts this lever

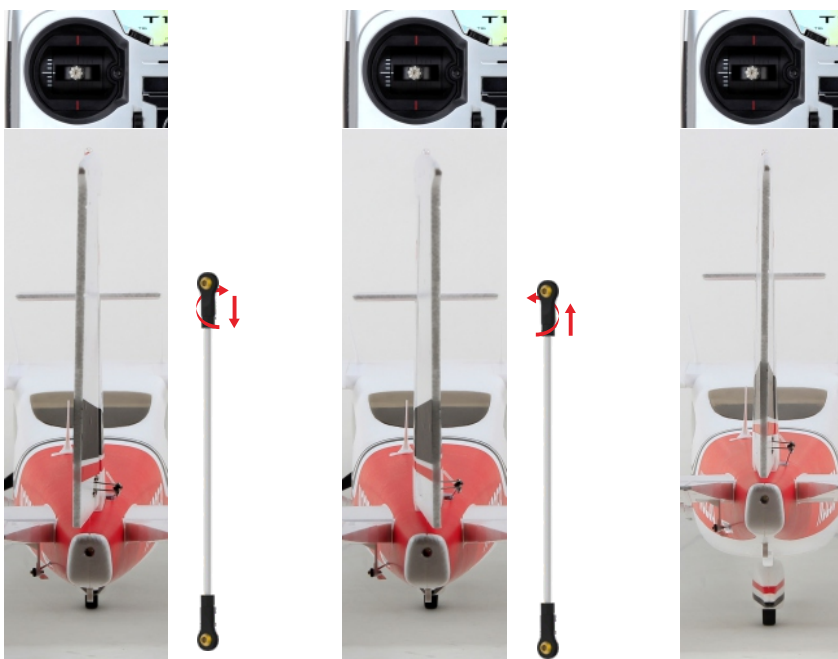
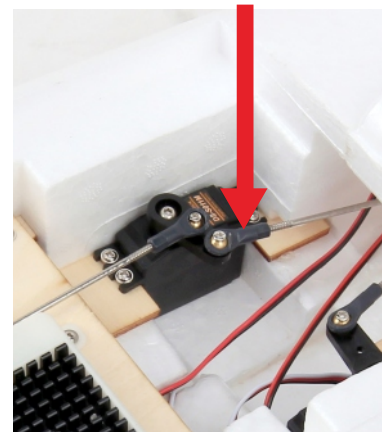

Physical adjustment

## First test and adjustment after assembly

**11. Flap detection:** check whether the flaps are correct

Right model throttle radio transmitter

Flaps standard action



**Flap compensation:** factory default compensation of 6%, customers can increase or decrease according to their own needs;

**12. Flaps adjustment:** After finishing the setting, start to check the flap rudder surface, whether the first gear flap rudder surface is the same in length, whether the second gear flap rudder surface is the same, if the two sides of the rudder surface are inconsistent, you can pass Physical adjustment; Physical adjustment: Change the length of the rudder surface by adjusting the length of the lever to keep it at the same degree with the two rudder surfaces. It is recommended to use 100% rudder for remote control, but it should be adjusted according to personal operating habits.

**It is suggested to use 100% rudder for remote control, which should be adjusted according to personal operating habits.**

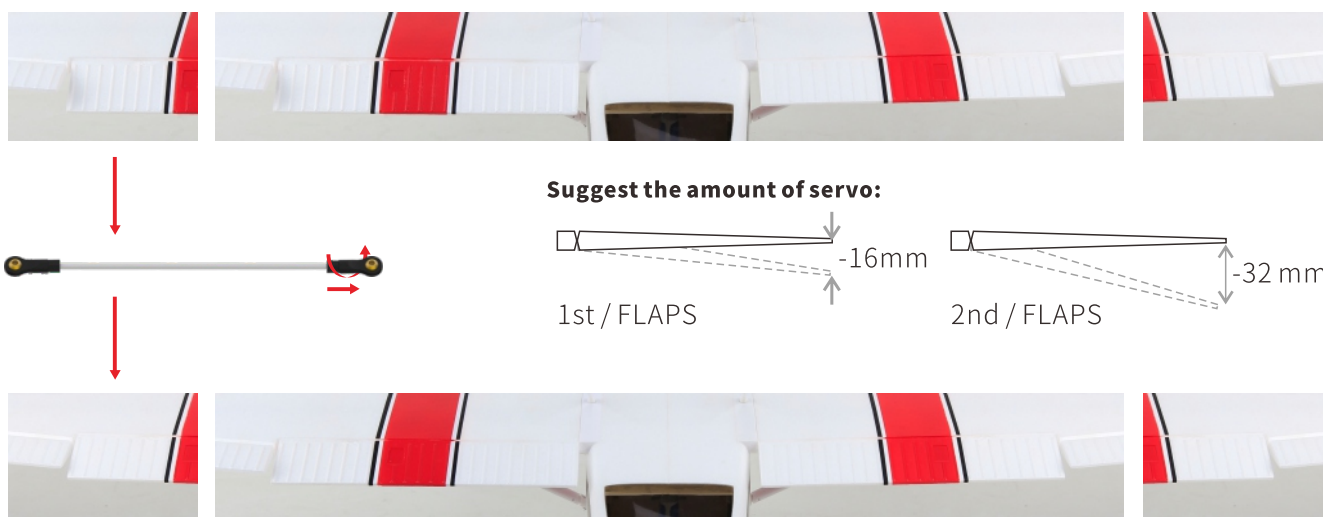

## First test and adjustment after assembly

**13. Ground interview and adjustment:** After the above steps are completed step by step, power on the machine for a straight run test to check whether the stroke of the front wheel steering gear is satisfied. System adjustment:

(1). Steering yaw adjustment:

1. Physical adjustment: by adjusting the length of the front wheel steering rod;
2. System adjustment: by adjusting the remote-control stroke.

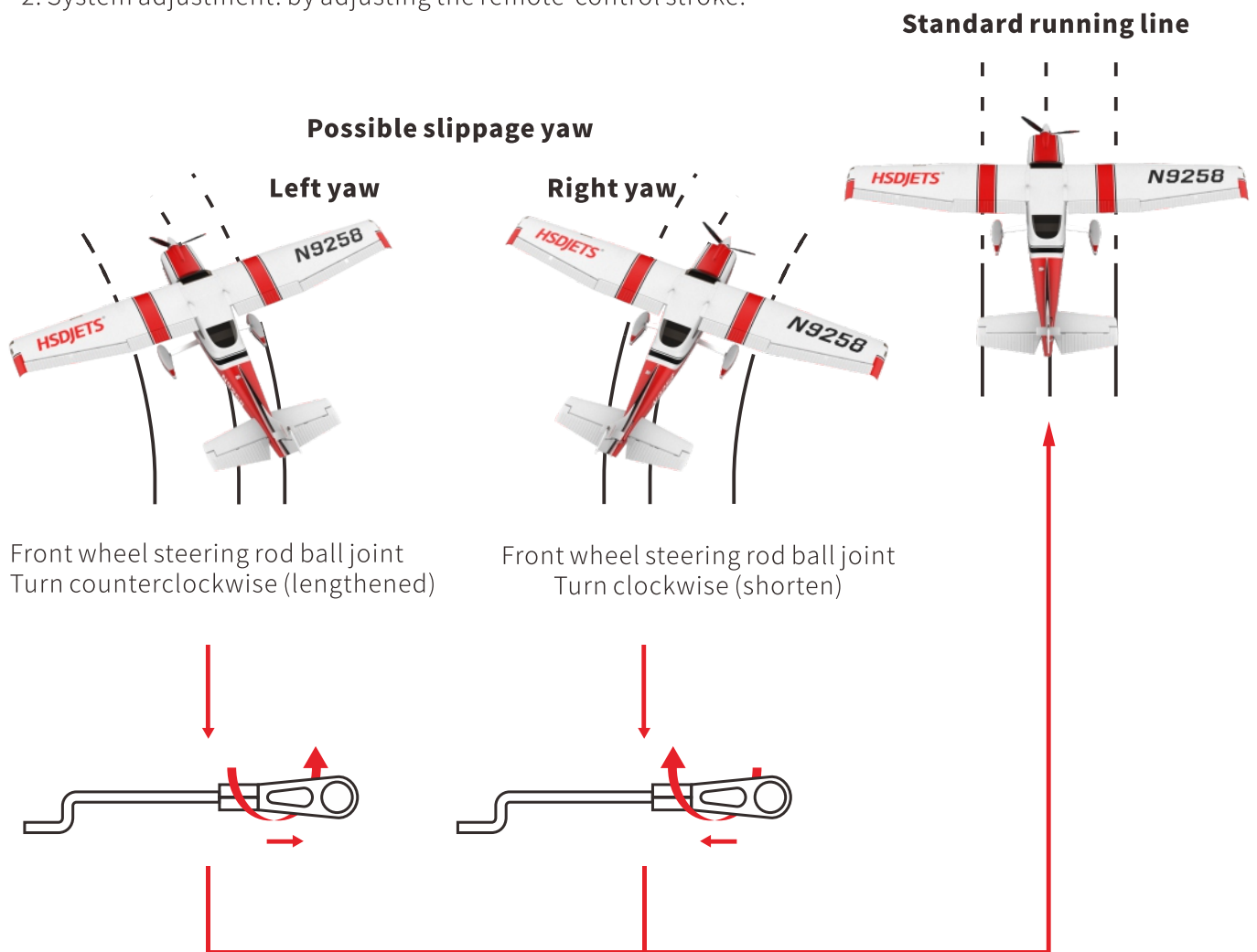

Front wheel deflection  
Adjust the lever

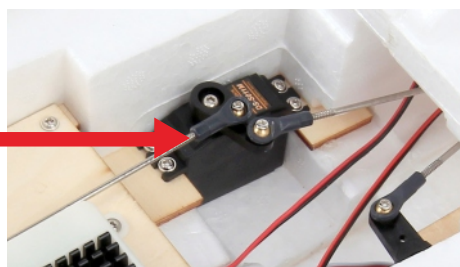

## First test and adjustment after assembly

### 14.Center of gravity detection before take-off:

Before starting the machine, you need to confirm whether the position of the center of gravity of the machine is correct. The center of gravity is located behind the front edge of the main wing: 96mm.



A general method for measuring the center of gravity

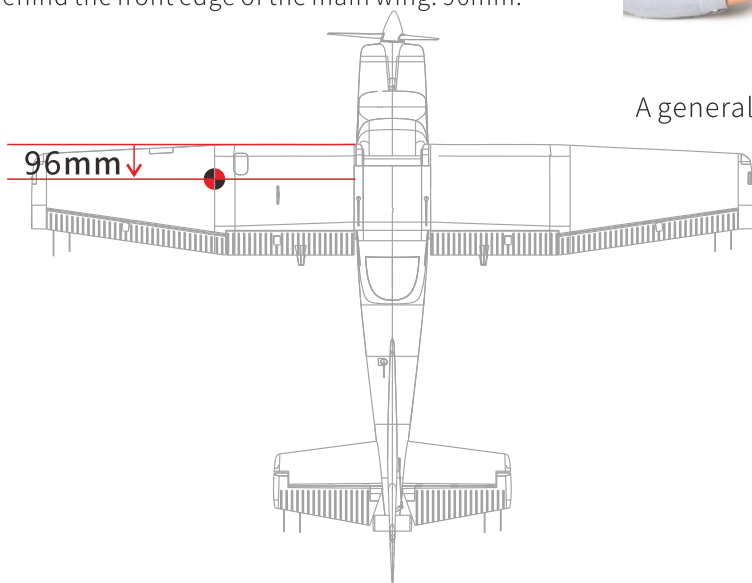

### Battery assembly diagram

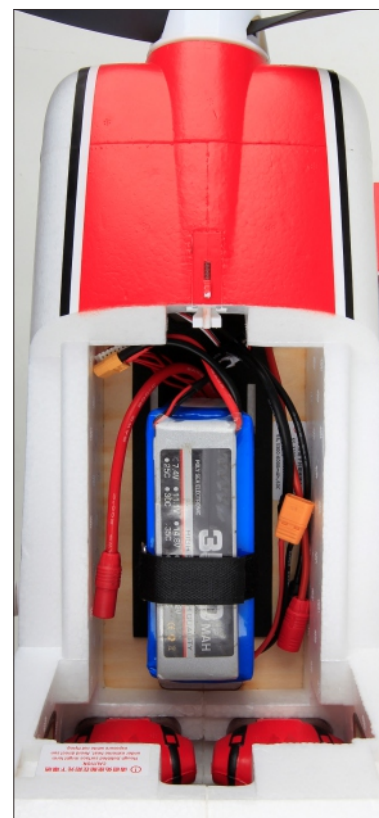

### 15.Center of gravity adjustment:

If the position of the center of gravity is wrong, it must be adjusted. Generally, there are two situations:

A.If the nose is too heavy (lower your head during ground center of gravity test), you can move the battery back to the rear of the aircraft or replace with a smaller capacity battery that can meet the power requirements of the aircraft;  
 B.The machine head is too light (head up during the ground center of gravity test), move the battery forward to the machine head or increase the counterweight or replace with a larger capacity battery that can meet the power requirements of the machine.

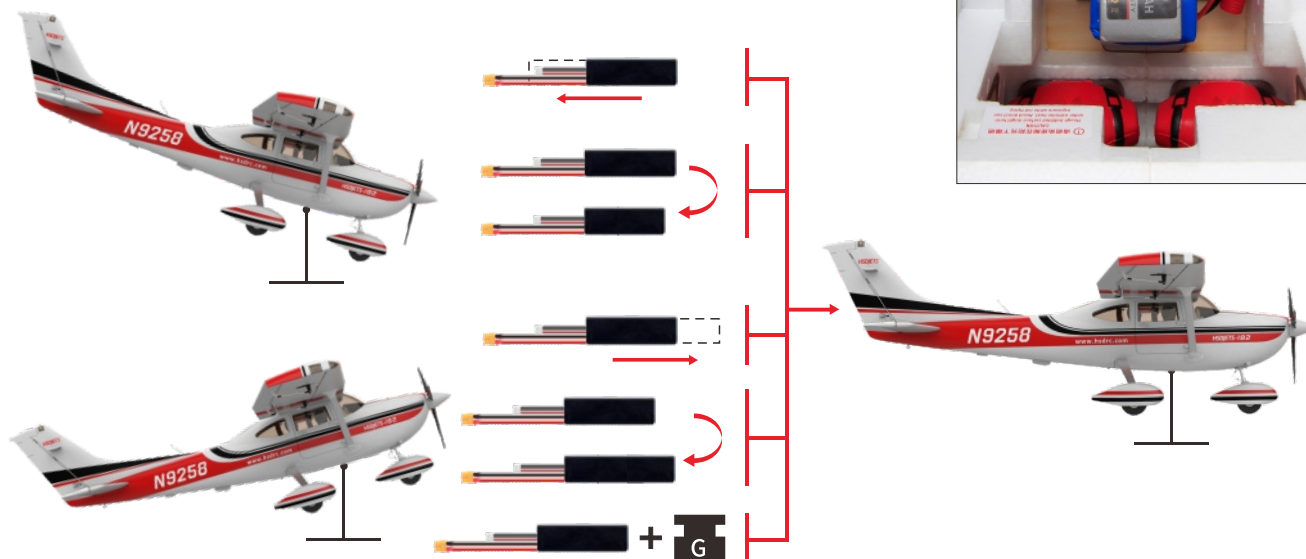



## Rear landing gear decomposition graph

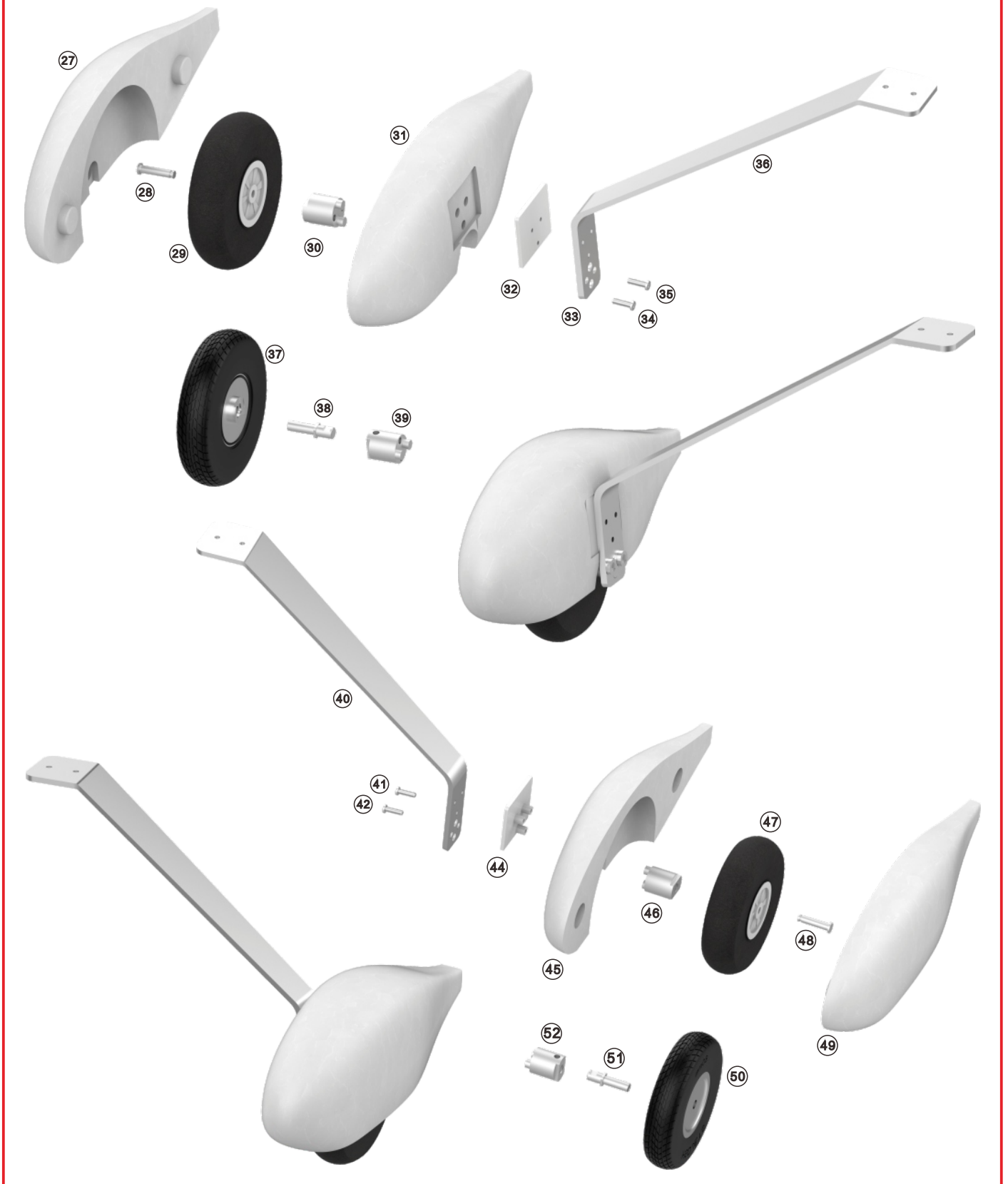

## Specification and configuration

### Specifications:

Wingspan	2000 mm / 78.7 in
Length	1586 mm / 62.4 in
Take off weight	4.7kg / 10.3 lb (with 22.2v 5200mAh 45C battery)
Crusing speed	80~90 km/h
Flying time	8~10 minutes
Main wing area	56.1 dm <sup>2</sup>
Loading of airfoil surface	83.8 g/dm <sup>2</sup>
Main material	35 times the import of aeromodelling EPO
Body Surface Treatment	Matte environmental water-borne paint (Part) + decal
Suitable experience level	<input type="checkbox"/> Zero basis <input checked="" type="checkbox"/> Beginner <input type="checkbox"/> Intermediate <input type="checkbox"/> Advanced
PNP assembly difficulty	<input checked="" type="checkbox"/> ☆(10mins) <input type="checkbox"/> ★☆(30mins) <input type="checkbox"/> ★★(60mins)
Operate suitable for age	Above 14 years of age
Working temperature	0°C ~ 40°C

### Configuration:

Remote control channel	6CH (Selective configuration)
Remote control system	MFC-2065
Motor	5055,KV500
ESC	Hobbywing 80A
Propeller	14.5×7 Trefoil oar
Power battery	22.2V, 5000~6000 mAh, 45C Li-Po (Selective configuration)
Receiver battery	7.4V, 2000~3000 mAh, 15C Li-Po (Selective configuration)
Servo	7.4V, 25g×6 PCS (High Voltage Metal Gear Digital)
Landing gear	Front three-point all-metal fixed landing gear
LED Lighting System	Yes
Aileron	Yes
Flaps	Yes
Horizontal tail	Yes
Vertical tail	Yes
Brake function	Selective configuration
Reinforced gyro	Selective configuration
Packaging	Inner box + Outer Box (with marks)
Center of gravity	96 mm leading edge of main wing
Packing dimensions	about 1415×375×370 mm / 55.71×14.76×14.57 in
Packing weight	about 7kg / 15.4 lb



HSDJETS WeChat

🌐 [www.hsdr.com](http://www.hsdr.com)    [www.hsdedf.com](http://www.hsdedf.com)    [www.hsdgo.com](http://www.hsdgo.com)

✉ [hsd@hsdjetshuang sai.com](mailto:hsd@hsdjetshuang sai.com)

📍 Company address : HSD Industry Park, Aigang Industry District, Huaide, Humen Town, Dongguan City, Guangdong Province, China (Post: 523926)

📍 Production address : Building A3, zhihuiyu intelligent equipment Industrial Park, 168 Chengxin Avenue, Xinfeng County, Ganzhou City, Jiangxi Province (Post: 561099)