

Thank you for purchasing a Futaba R3204SB T-FHSS Air-2.4GHz compatible receiver. The R3204SB receiver features bi-directional communication with a T-FHSS Air-2.4GHz Futaba transmitter using the S.BUS2 port. Using the S.BUS2 port an impressive array of telemetry sensors may be utilized.

### Applicable systems: Futaba T-FHSS Air 2.4GHz system

#### Usage precaution

- Futaba T-FHSS Air system does not work with current Futaba FASST/FASSTest/S-FHSS/T-FHSS Car system. Futaba FASST/FASSTest/S-FHSS/T-FHSS Car system and T-FHSS Air system are not compatible to each other.

#### ⚠ WARNING

- ❗ **Wrap the receiver with something soft, such as foam rubber, to avoid vibration. Moreover, the receiver must not get wet.**
- ⊘ **Do not short-circuit the connectors.**
- ⊘ **Do not expose the receiver to high temperatures.**
  - The shrink cover could become distorted.
- ⊘ **Do not break the tube.**
  - Could cause a short circuit.
- ❗ **When inserting and removing a connector, hold the receiver tightly.**
  - Be careful so that a tube doesn't come off.

#### Antenna installation precaution

- ⊘ **Do not cut or bundle the receiver antenna wire.**
  - ⊘ **Do not bend the coaxial cable. It causes damage.**
  - ❗ **The antenna should not be pulled.**
  - ❗ **Keep the antenna as far away from the motor, ESC and other noise sources as you possibly can.**
  - ⊘ **Do not touch the antenna to metal, carbon, or other conductive material.**
  - ❗ **Be sure that the two antennas are placed at 90 degrees to each other.**
    - The two antennas act as diversity system in order to keep the condition of the signal reception as better as possible in any aircraft's attitude.
- #### Antenna installation for carbon fuse
- ⚠ **WARNING**
- ❗ **The antenna portion of 30mm tip must be fully exposed.**
    - Please make sure that the exposed portion won't slide back in the fuse due to wind pressure or other force during the flight session.

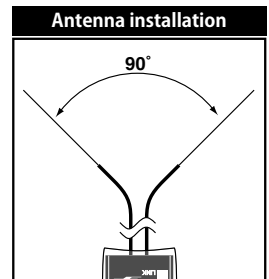
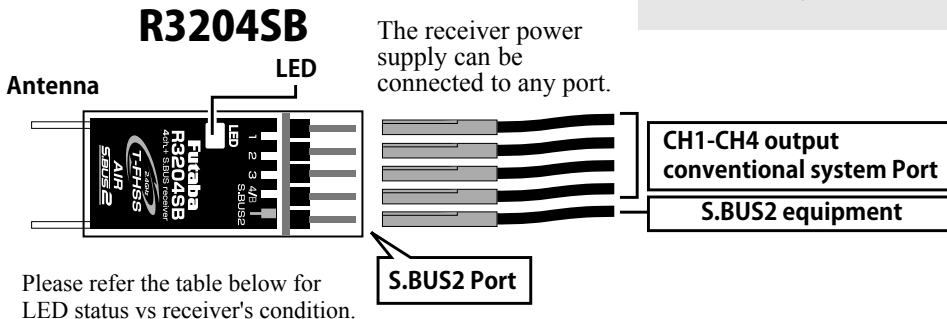

#### LED Indication

LED	Status
Solid	Receiving signals
1 time blink	Waiting for link
2 times blink	No signal reception
2 times blink (Every 4 seconds)	Unrecoverable error (Memory, etc.)

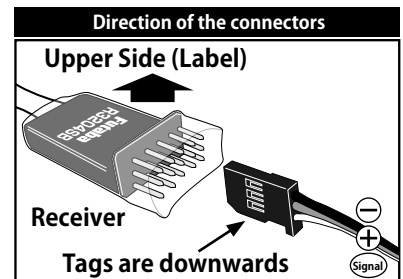

#### Compliance Information Statement (for U.S.A.)

This device, trade name Futaba Corporation, model number R3204SB, complies with part15 of the FCC Rules. Operation is subject to the following two conditions:

- (1) This device may not cause harmful interference, and
- (2) This device must accept any interference received, including interference that may cause undesired operation.

CAUTION: To assure continued FCC compliance

1. Any changes or modifications not expressly approved by the grantee of this device could void the user's authority to operate the equipment.
2. This equipment complies with FCC radiation exposure limits set forth for an uncontrolled environment.

This equipment should be installed and operated with minimum distance 20cm between the radiator & your body.

The responsible party of this device compliance is:

FUTABA Corporation of America

2681 Wall Triana Hwy Huntsville, AL 35824, U.S.A.

Phone: 1-256-461-9399 FAX: 1-256-461-1059 E-mail: service@futabaUSA.com

#### Declaration of Conformity (for EU)

Hereby, Futaba Corporation declares that the radio equipment type is R3204SB in compliance with Directive 2014/53/EU. The full text of the EU declaration of conformity is available at the following internet address:

<http://www.rc.futaba.co.jp/english/dl/declarations.html>

#### Compliance Information Statement (for Canada)

This device complies with Industry Canada license-exempt RSS standard(s). Operation is subject to the following two conditions: (1) this device may not cause interference, and (2) this device must accept any interference, including interference that may cause undesired operation of the device. This equipment complies with IC radiation exposure limits set forth for an uncontrolled environment. This equipment should be installed and operated with minimum distance 20cm between the radiator & your body.

French: Cet appareil radio est conforme au CNR-210 d'Industrie Canada. L'utilisation de ce dispositif est autorisée seulement aux deux conditions suivantes : (1) il ne doit pas produire de brouillage, et (2) l'utilisateur du dispositif doit être prêt à accepter tout brouillage radioélectrique reçu, même sice brouillage est susceptible de compromettre le fonctionnement du dispositif. Cet équipement est conforme aux limites d'exposition aux rayonnements IC établies pour un environnement non contrôlé.

Cet équipement est conforme aux limites d'exposition aux rayonnements IC établies pour un environnement non contrôlé. Cet équipement doit être installé et utilisé avec un minimum de 20 cm de distance entre la source de rayonnement et votre corps.

## e.g. Telemetry system

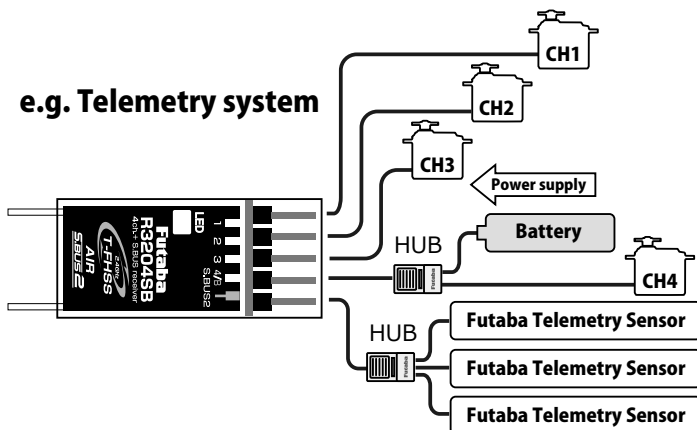

### R3204SB Specifications

T-FHSS Air 2.4GHz system/S.BUS2 port and 4 channels for conventional system receiver

- Dual antenna diversity
- Size: 0.71 x 1.63 x 0.39 in. (18.0 x 41.4 x 9.9 mm)
- Weight: 0.17 oz. (4.8g)
- Power requirement: 3.7 V to 7.4 V (Voltage range: 3.5 V to 8.4 V)
- Battery F/S Voltage: It sets up with a transmitter  
\*Turn off Battery F/S when using 1cell(3.8V or less)  
To check the receiver voltage, use the telemetry receiver voltage alarm setting function.
- Frequency band: 2.4GHz band
- RF power output: 25mW EIRP

\* Be sure that when using ESC's regulated output the current capacity of the ESC meets your usage condition.

\* S.BUS2 port: R3204SB can be used with up to 18 channels. However, it differs according to the transmitter. An unused channel is a neutral signal. The F/S setting channel at F/S is F/S position. Another, it is Hold signal.

## Link to the transmitter

Please link the receiver to the transmitter by the process shown below.

- 1 Bring the transmitter and the receiver close to each other, within 20 inches (half meter).
- 2 Turn on the transmitter. Place the transmitter into the receiver linking mode.
- 3 Turn on the receiver.
- 4 The receiver will accept the link command from the transmitter for 5 seconds. The receiver will back to normal operation if fail to link, so that when need to try linking again please turn off the receiver and back to step 2.
- 5 When the link is completed, the LED on the receiver changes to solid.

\* Refer to the transmitters operation manual for complete details on how to place the transmitter into the linking mode.

\* If there are many T-FHSS Air systems turned on in close proximity, your receiver might have difficulty establishing a link to your transmitter. This is a rare occurrence. However, should another T-FHSS Air transmitter/receiver be linking at the same time, your receiver could link to the wrong transmitter. This is very dangerous if you do not notice this situation. In order to avoid the problem, we strongly recommend you to double check whether your receiver is really under control by your transmitter.

\* If the System Type of the transmitter is changed, the receiver will need to be re-linked to the transmitter.

\* Link is required when a new model is made from a model selection.

### ⚠ WARNING

⚠ Do not perform the linking procedure while the motor's main wire connected or the engine is operating as it may result in serious injury.

⚠ When the linking is complete, please cycle the receiver power and ensure the receiver is properly linked to the transmitter.

⚠ Please power up your system in this order in order to avoid unconscious behavior of the servo/ESC. Transmitter first, followed by the receiver.

⚠ If the R3204SB about to link was previously linked with other transmitter, make sure the transmitter previously linked is turned off while linking with new transmitter to be linked.

## What is S.BUS2?

Different from conventional radio control systems, the S.BUS2 system uses data communication to transmit control signals from a receiver to a servo, gyro, or other S.BUS2 compatible devices. This data includes commands such as "move the channel 3 servo to 15 degrees, move the channel 5 servo to 30 degrees" to multiple devices. The S.BUS2 devices execute only those commands for their own set channel. For this reason, it can be used by connecting multiple servos to the same signal line. S.BUS devices can not be connected to S.BUS2 port.

### ⚠ WARNING

⚠ Turn on the power on transmitter → receiver in order. In addition, always check the operation of all the functions before flight.

### ⚠ WARNING

⚠ Do not insert or remove the S.BUS2 connector while the receiver power is ON.

Since the S.BUS2 servo switches the operation mode automatically according to the type of signal (S.BUS2 signal/PWM signal) from the receiver, if the connector is inserted or removed while the power is ON, an S.BUS2 connected servo will be erroneously recognized and may stop.

### Connection by S.BUS2 system

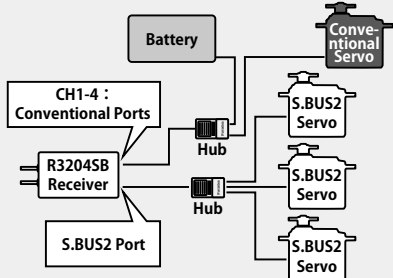

● Can also be used together with conventional servo. (1-4 channels)

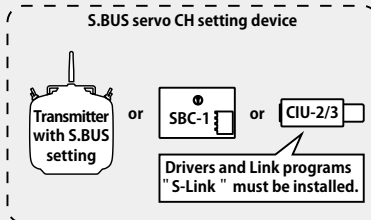

FUTABA CORPORATION  
Hobby Radio Control Business Center Sales & Marketing Department  
1080 Yabutsuka, Chosei-mura, Chosei-gun, Chiba-ken, 299-4395, Japan  
TEL: +81-475-32-6051, FAX: +81-475-32-2915