

# ESKY150 V2

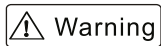

## Safety Precautions and Warnings

RC helicopter is controlled by radio signals. It may be interfered by other radio signals during operation. These interference may cause the helicopter lose control.



1. Improper operation to Esky 150V2 may lead to damage or loss. It is prohibited for children under 14 years to operate this product.
2. Keep it away from high temperature environment for storage and flight.
3. Suggested operation temperature: 5-35°C; Humidity: 20-80%
4. Keep away from fan, air conditioner, table light while flying.
5. Do not contact the motor in case of damage or injury.

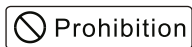

1. Keep away from crowds in case of accidents.
2. Do not operate Esky150V2 in shower room or under rain. Moisture may go inside the helicopter which may cause electronic parts malfunction and unexpected incident.
3. Do not re-equip, upgrade or repair your helicopter with unauthorized parts.
4. Keep people and objects away from the spinning unit and parts in case of damage or injury.

## Charging the LiPo Battery by USB Charger

- 1) Plug the 3.7v LiPo Battery into the USB charger
- 2) Plug the USB charger into the USB port of computer or charger. Then there is a solid red light on the USB charger's LED indicator.
- 3) When the LiPo Battery is fully charged, the red light will change to green light.

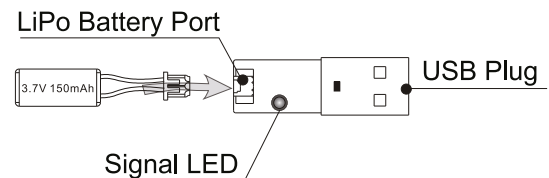

## Helicopter Parts

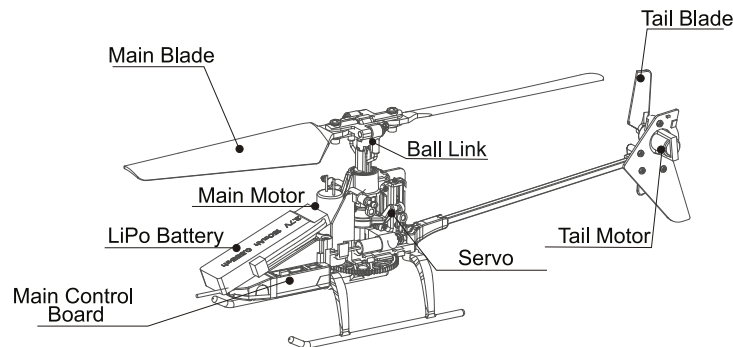

## Binding

- 1) Switch off transmitter, switch on helicopter, the condition green LED from helicopter flashes rapidly in a short period of time.
- 2) Push and hold the Rudder Trim Lever to right and Power Switch on the transmitter.
- 3) When the condition LED from helicopter is light up which implies the binding is completed, release the Rudder Trim Lever and Power Switch from the transmitter. (Helicopter was completely binded in the factory setting)

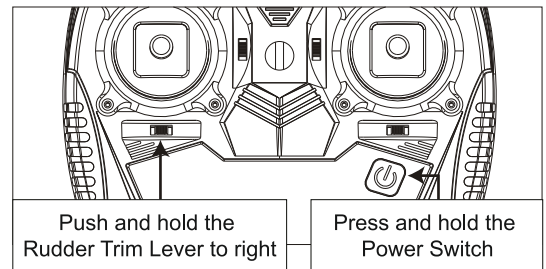

# Flight Operation Procedure - Left hand throttle transmitter Mode 2

## Preflight Procedure

- 1) Set the **Left Stick** down to bottom and power on the transmitter.
- 2) Put the helicopter on the ground or flat, power on the helicopter, make sure the helicopter remains flat until the helicopter pass the self-testing.(Condition Blue LED from quick flashing to slow flashing in the indicator)
- 3) Safety Unlock:

### Left hand throttle transmitter - Mode 2



Keep the **Left Stick** down to bottom, then pushing the **Left Stick** to Right or at least 3 seconds and release.

## End Flight Procedure

- 1) Power Off the Helicopter
- 2) Power off the Transmitter

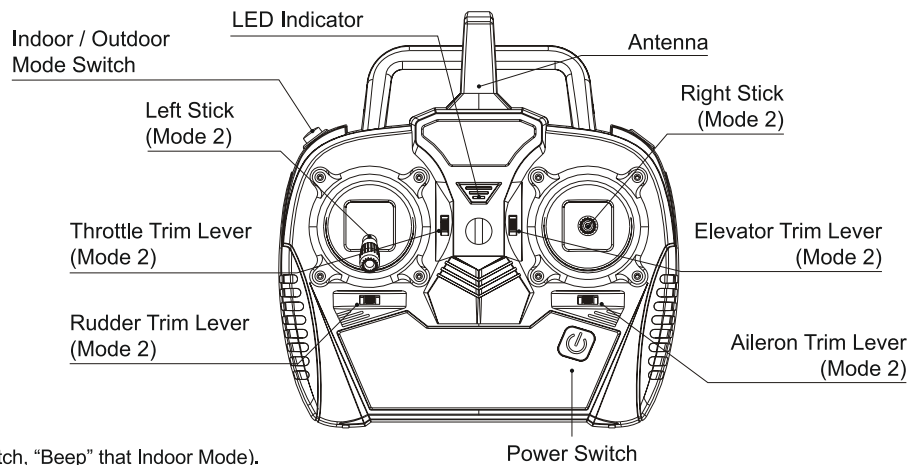

P.S. Indoor Mode (Press Indoor/Outdoor Mode Switch, "Beep" that Indoor Mode).  
 Outdoor Mode (Press Indoor/Outdoor Mode Switch, "Beep""Beep" that Outdoor Mode).  
 Indoor Mode defaulted when turn on the transmitter, it was recommended to landing before switch mode.

## Transmitter Control

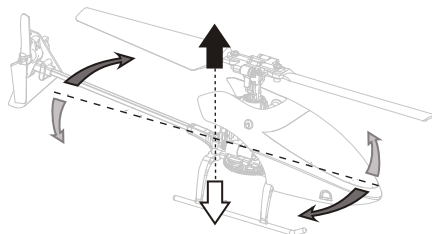

Mode 2

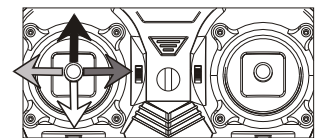

When pushing the "Left Stick" up or down, the helicopter lifts up or decends accordingly; This procedure is Throttle control.  
 When pushing the "Left Stick" left or right, the head of the helicopter turns left or right accordingly; This procedure is Rudder control.

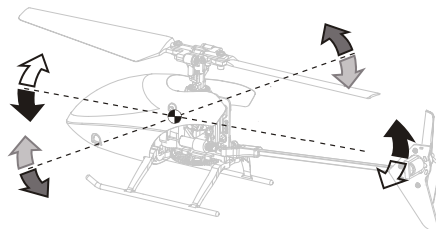

Mode 2

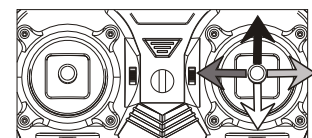

When pushing the "Right Stick" up or down, the helicopter moves forward or backward accordingly; This procedure is Elevator control.  
 When pushing the "Right Stick" left or right, the helicopter tilts left or right accordingly; This procedure is Aileron control.

# Flight Operation Procedure - Right hand throttle transmitter Mode 1

## Preflight Procedure

- 1) Set the **Right Stick** down to bottom and power on the transmitter.
- 2) Put the helicopter on the ground or flat, power on the helicopter, make sure the helicopter remains flat until the helicopter pass the self-testing.(Condition Blue LED from quick flashing to slow flashing in the indicator)
- 3) Safety Unlock:

Keep the **Right Stick** down to bottom, then pushing the **Left Stick** to Right or at least 3 seconds and release.

## End Flight Procedure

- 1) Power Off the Helicopter
- 2) Power off the Transmitter

### Right hand throttle transmitter - Mode 1

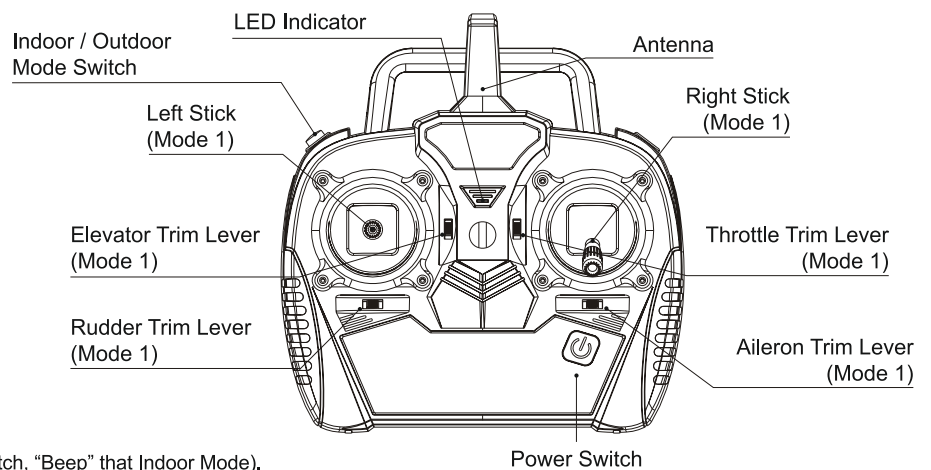
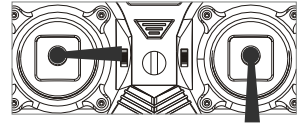

P.S. Indoor Mode (Press Indoor/Outdoor Mode Switch, "Beep" that Indoor Mode).  
 Outdoor Mode (Press Indoor/Outdoor Mode Switch, "Beep""Beep" that Outdoor Mode).  
 Indoor Mode defaulted when turn on the transmitter, it was recommended to landing before switch mode.

## Transmitter Control

Mode 1

When pushing the "Right Stick" up or down, the helicopter lifts up or descends accordingly; This procedure is Throttle control.  
 When pushing the "Left Stick" left or right, the head of the helicopter turns left or right accordingly; This procedure is Rudder control.

Mode 1

When pushing the "Left Stick" up or down, the helicopter moves forward or backward accordingly; This procedure is Elevator control.  
 When pushing the "Right Stick" left or right, the helicopter tilts left or right accordingly; This procedure is Aileron control.

## Command Problems FAQ

Situation	Reason	Solution
Why the battery bulge before second flight?	Over discharge the battery	Replace a new battery
Why the helicopter not stable when flight?	Due to some parts fixed error	Adjust by trim lever
Why the helicopter green light being slow flash?	LiPo battery low voltage protection	Charge the LiPo battery
Why the green light do not solid on the helicopter?	Do not receive any signal	Rebind or Reboot the Transmitter
How do I know when a battery is 100% charged?	When the charger light from red to green	
What is the function of the indoor / outdoor mode switch?	To switch the flight mode and sensitive mode for different user	
Heavily skewed when flight	Linking parts separated	Check each linking parts
Heavily unstable when flight	Sensor swot analysis mistakes	Reboot the helicopter

P.S. The development of ESKY 150 V2 would not have been possible without the effort of a large team of individuals who invested in the open source flight controller software that running on the ESKY 150 V2.

## Spare Parts

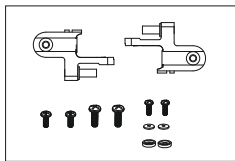

ESKY006310

Main Rotor Blade Grip Set

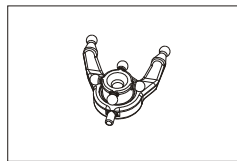

ESKY006404

Swashplate Set

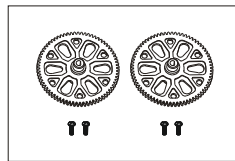

ESKY006311

Main Gear

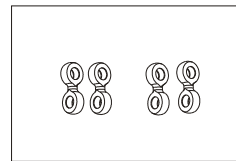

ESKY006406

Pushrod Set for Servo

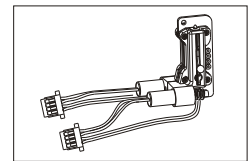

ESKY006407

Line Servo Set

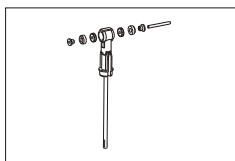

ESKY006408

Main Rotor Housing Set

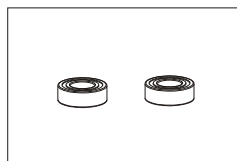

ESKY005439

Bearing: 3\*6\*2

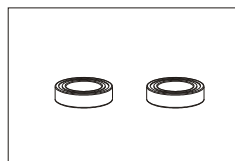

ESKY005805

Bearing: 5\*8\*2

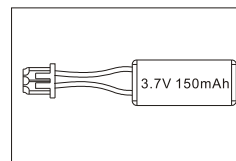

ESKY005435a

LiPo Battery : 150mAh

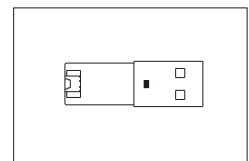

ESKY006007

USB Charger

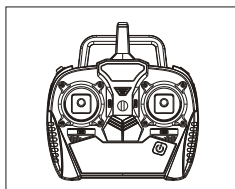

ESKY007324

Transmitter Mode 2

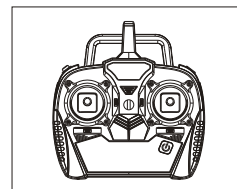

ESKY007324a

Transmitter Mode 1

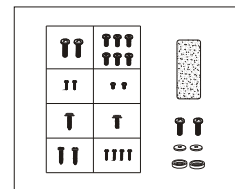

ESKY006316

Screws Set

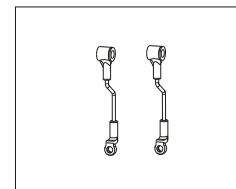

ESKY006405

Pushrod Set

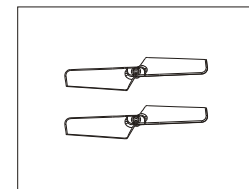

ESKY006403

Tail Blade

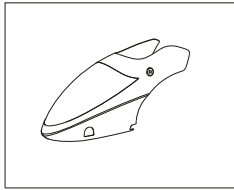

ESKY007322  
Canopy

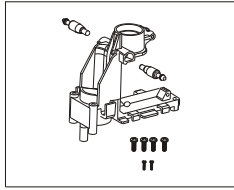

ESKY006318  
Main Frame

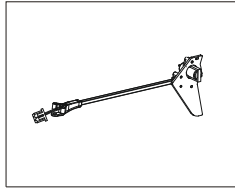

ESKY007323  
Tail Mount with Motor and LED

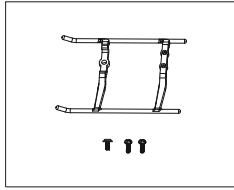

ESKY006320  
Landing Skid

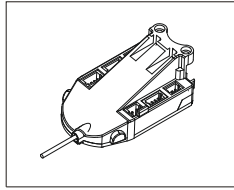

ESKY007317  
5 in 1 Control Unit

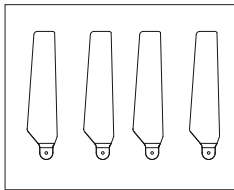

ESKY006402  
Main Blade Set

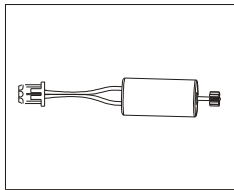

ESKY006313  
Main Motor

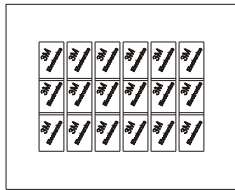

ESKY007024  
Double Sided Sticker

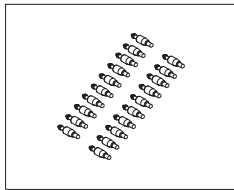

ESKY007164  
Canopy Mount Set

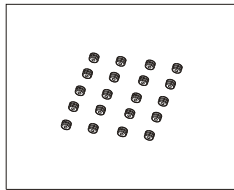

ESKY007205  
Canopy O Ring Set

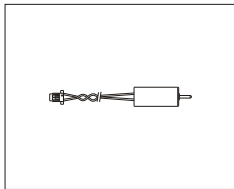

ESKY007220  
Tail Motor