

Electric Retracts

15-25 Size Electric Retracts

INSTRUCTION MANUAL

Thank you for purchasing these Aircraft Mechanic Electric Retracts. These self-contained units are designed to be simple to install. They are powered from your model's receiver and do not require separate servos or tricky linkages.

Note: Mains and Nose retracts are sold separately.

The main retracts are supplied with coiled wire struts installed, plus adjustable axles, wheel collars, hex wrenches and a 3-into-1 wiring harness.

The nose gear unit is steerable and has a slot in the sliding steering arm to prevent binding of the steering pushrod when retracted and is supplied with an adjustable axle, wheel collar and hex wrenches.

Specifications

(Subject to change or improvement without notice.)

- Current draw at idle: 5mA
- Operating current 200mA (maximum)
- Pulse width trigger points: Down 1.331ms, Up 1.690ms
- Operation with FM and DSM
- FM 22ms frame rate, 5V signal
- DSM 20ms frame rate, 3.3V signal
- Sequence time: @ 4.8V 1.25sec, @ 6.0V 1.00sec, @ 7.4V 0.75sec
- Operating voltage range: 4.8 – 7.4V
- Aircraft weight: 1.80kg – 3.20kg
- Unit weight: Nose gear 48.0g
- Main gear 39.5g each

BOX CONTENTS

(Mains and Nose retracts sold separately)

4406330 - Electric Retracts 15-25 Main Set And Legs (2)

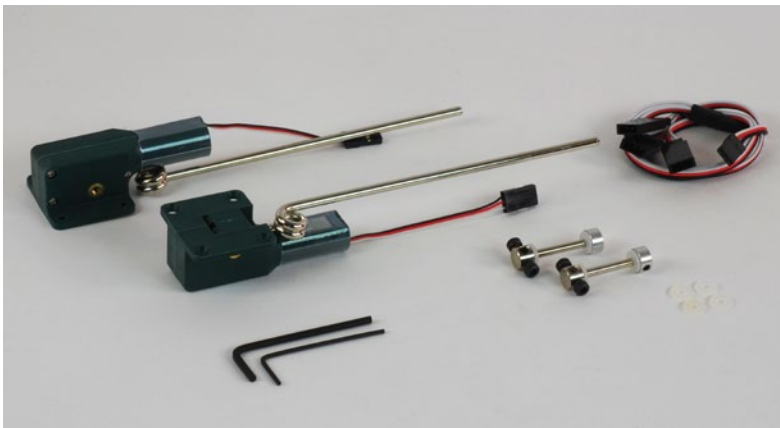

Includes two (2) Aircraft Mechanics 15-25 size 90° electric retract units, wire legs, 3-into-1 extension lead, adjustable axles, wheel retaining collets and hex wrenches.

4406325 - Electric Retracts 15-25 Nose Set And Leg (1)

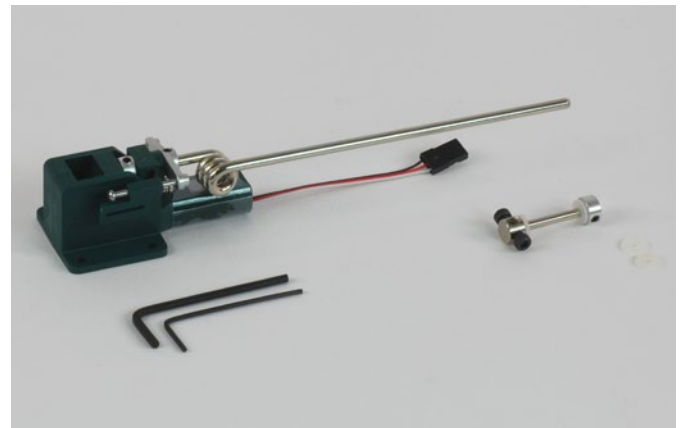

Includes one (1) Aircraft Mechanics 15-25 size 90° electric retract nose unit, wire leg, adjustable axle, wheel retaining collet and hex wrenches.

WARNING:

- Read the ENTIRE instruction manual to become familiar with the features of these electric retracts before operating.
- These are sophisticated hobby products. They must be operated with caution and common sense and require some basic mechanical ability. Failure to operate this product in a safe and responsible manner could result in injury, damage to the product or other property.
- This product is not intended for use by children without direct adult supervision.
- Do not attempt to disassemble, use with incompatible components or modify the product in any way.
- It is essential to read and follow all the instructions and warnings in the manual, prior to assembly, setup or use, in order to operate correctly and avoid damage or serious injury.
- Age Recommendation: Not for children under 14 years. This is not a toy.

INSTALLATION

WARNING: Always ensure the retracts and wheels are installed so that there are no obstructions when extending and retracting the struts and that the wheels roll straight when the rudder is at neutral. Failure to do so could result in damage to the aircraft or gear.

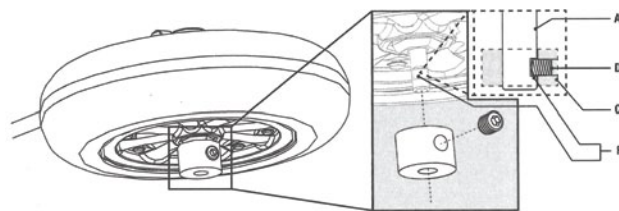
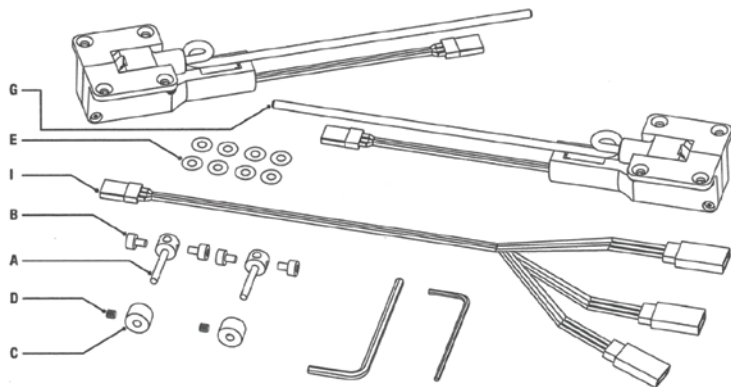

1. Loosely assemble an axle (A), screws (B), your choice of wheel and wheel collar (C) and set screw (D) on each retract strut. If needed, use nylon washers (E) as spacers to prevent the wheel from rubbing on the strut.
2. Tighten the set screw in each wheel collar to mark the axle.
3. Loosen the set screw, remove the wheel collar and use a file to make a flat spot (F) at the place you marked, then replace the collar on the axle. Use thread lock when tightening the set screw.

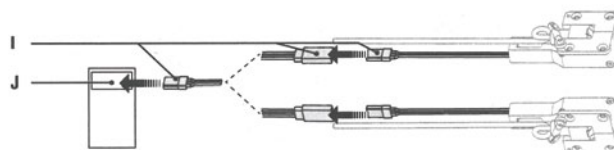
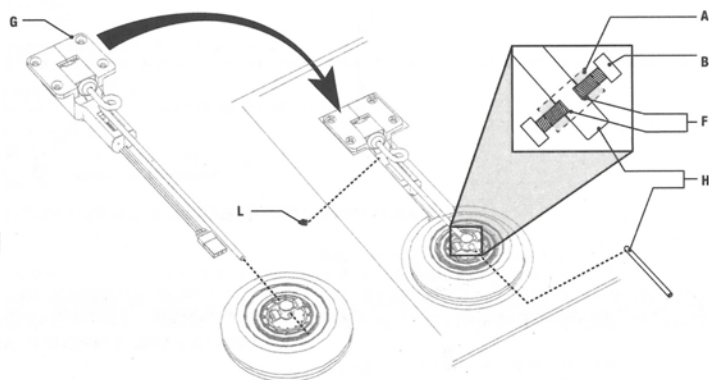

4. Connect the retracts to your receiver and extend the struts (if needed) to position the units in your aircraft. Mark the screw positions using the screw holes in the retract.
5. Install the mains retracts in your aircraft (right retract (G) shown) using #4 x 1/2" or M3 countersunk wood screws. If you are also installing a nose retract, follow the same procedure.

If installing these retracts on wooden mounting rails, pre-drill holes smaller than your mounting screws first. Install the mounting screws in the drilled holes, then carefully remove them. Harden the threads in the wood using thin CA (cyanoacrylate adhesive).

6. Operate the gear and position the wheel in the centre of the wheel well, then mark strut (H) for length.
7. Operate the gear and position the axle assembly on the strut so that the aircraft rolls straight, then tighten the axle screw to mark the strut.
8. Remove the axle assembly, cut the strut (H) to length and file flat spots (F) on the strut where you previously marked it.
9. Install the axle assembly on the strut and tighten screws using threadlock. A single setscrew (L) holds the strut into the retract unit.

RADIO CONNECTIONS AND OPERATION

Use caution when connecting all extension leads so you maintain correct battery polarity. The BLACK wire is negative (-), the RED wire is positive (+) and the WHITE wire is signal (⏏).

1. Plug the lead on each retract unit into the supplied 3-into-1 extension lead, then plug the male end of the 3-into-1 extension lead into the retract channel on your receiver. (Depending on the brand of radio, you may use the Aux or another channel you have set aside for retracts).
2. Power on your transmitter and then your receiver.
3. Operate the channel control on your transmitter to which you have connected the gear.
4. The gear channel may need to be reversed in your transmitter for correct operation.

This product complies with the EU directive on Waste Electrical and Electronic Equipment. Do not dispose of this product in household waste. At the end of the product's life, dispose of it at a designated collection point for the recycling of waste electrical and electronic equipment. Please contact your supplier for any advice required on disposal.

Distributed in the UK and Europe by:
J Perkins (Distribution) Ltd, Lenham, England
www.jperkinsdistribution.co.uk

MADE IN CHINA

